

CAD FILE:

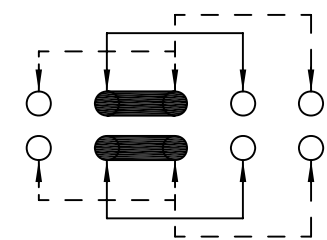

SCHEMATIC (SHORTING)

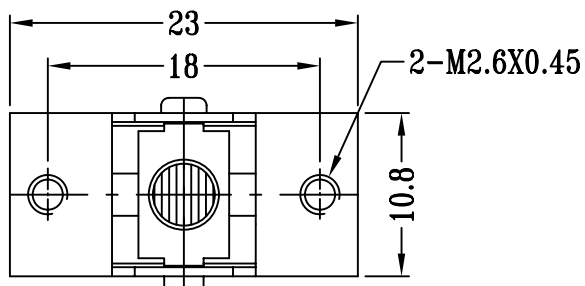
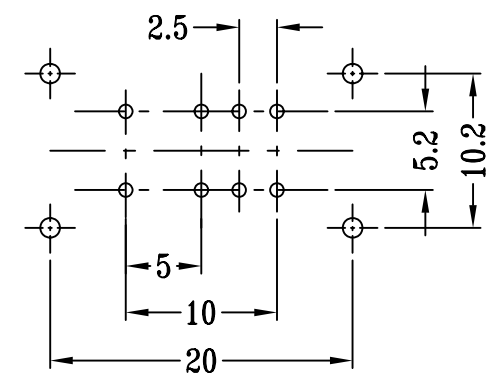
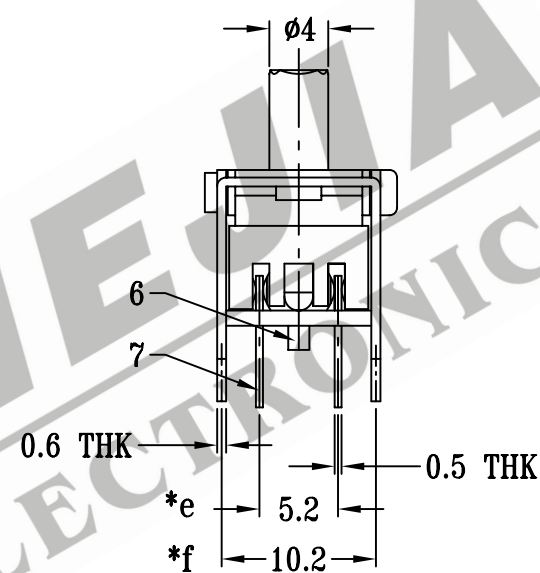
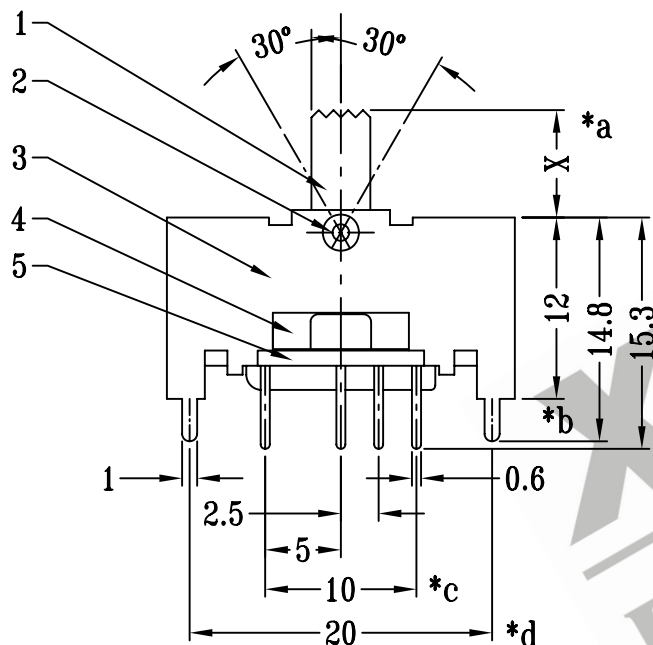

P.C.B LAYOUT

10	CONTACT (CLIP)	PBS	2	Ag CLAD
9	PRESS BAR	POM	1	WHITE
8	SPRING	STEEL WIRE	1	TEMPER
7	TERMINAL	BRASS STRIP	8	Ag PLATED OVER Ni PLATED
6	POSITION PLATE	POM	1	BLACK
5	BASE	PHENOLIC RESIN	1	NATURAL
4	SLIDER	POM	1	BLACK
3	FRAME	STEEL STRIP	1	Ni/Zn PLATED
2	RIVET	COPPER	1	Ni PLATED
1	KNOB	PC	1	BLACK
NO.	PARTS	MATERIALS	Q'TY	FINISH

TOLERANCE UNLESS SPECIFIED		SHENZHEN XIEJIA ELECTRONICS CO.,LTD.		
WITHIN: 1.5 ±0.1mm		ISSUE	DATE	DESCRIPTIONS OF REVISION
OVER: 1.5 ±0.2mm		APPD.		
TITLE : TOOGGLE SWITCH		UNIT : mm	DRWG NO.: XJ-DR-TS23E02-00	
MODEL: TS-23E02		SCALE: 2:1	DWN. ZHOUYU	2005-9-10
ALL MATERIALS MUST BE COMPLIANT TO ROHS			CHK'D FANGYING	2005-9-10
			APPD. KANGXINAN	2005-9-10

注:带"*"表示关键尺寸(6个)